

MT6100i

Human Machine Interface
with 10" TFT LCD display



◆◆ Features

- 10" 800x480 TFT LCD
- Fan-less cooling system
- Built-in flash memory and RTC
- NEMA4/IP65 compliant front panel
- LED Back Light
- One USB Host and one USB client port
- SD card slot
- Power Isolator inside
- Com1 RS485 supports MPI 187.5K

【Introduction】

MT6000 series is the new HMI generation of Weintek. With the design concept of meeting customers' satisfaction while easy-to-Use attribute as before, a MT6000 not only performs as a Human Machine Interface but also plays as a role of data exchange center. MT6000 series is the best choice for your requirement tomorrow.

The MT6100i is equipped with a USB 1.1 host, a USB 2.0 high speed device and SD card slot.

◆◆ Specifications

Construction: plastic molding housing

Display: 10" 65,536 color TFT LCD

CPU and core logic: 32Bit RISC 400MHz processor

DRAM: 64 MB DDR2 on board

Storage: 128 MB flash memory on board,

(User project size: 16MB, Data and Event log size: 48MB)

I/O: 3 serial ports: Com1: RS-232/RS-485 2w/4w,

Com2: RS-232,

Com3: RS-232/RS-485 2w

1 USB 1.1 host

1 USB 2.0 high speed device

RTC: Built-in

Power input: 24±20%V_{DC}, 300mA@24VDC

Dimension (W x H x D): 271 x 212 x 50mm

Weight: 1.4kg

Software: EB8000 V2.0.0 or later

◆◆ CD Display

Display type	TFT LCD
Display size (diagonal)	10"
Max colors	65536
Resolution	800 x 480
Viewing angle (°)	45/65/65/65(T/B/R/L)
Luminance (cd/m ²)	300
Backlight	LED
Backlight Life time	30,000 hrs.
Contrast ratio	500:1

◆◆ Touchscreen

Type: 4-wire, analog resistive

Resolution: continuous

Light transmission: above 80%

Life: 1 million activation minimum

◆◆ Environmental Specifications

Operating temperature: 0° ~ 50°C (32° ~ 122°F)

Storage temperature: -20° ~ 60°C (-4° ~ 140°F)

Relative humidity: 10% ~ 90% @ 40°C, non-condensing

Shock (operation): 10 to 25Hz(X,Y,Z direction 2G 30minutes)

CE/FCC: Complies with EN 55022:2006, Class A

EN 61000-3-2:2006

EN 61000-3-3:1995+A1:2001+A2:2005

EN 55024:1998+A1:2001+A2:2003

Front panel meets NEMA4 / IP65

MT6100i

◆ Dimensions Drawing

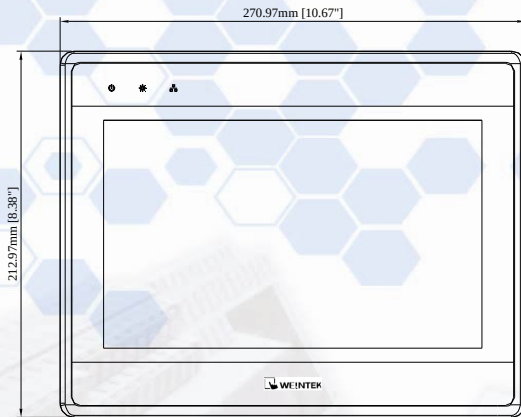

Front View

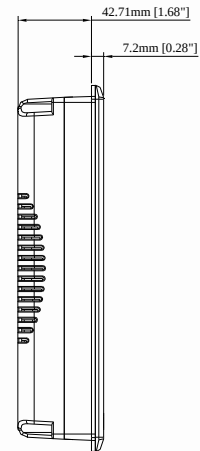

Side View

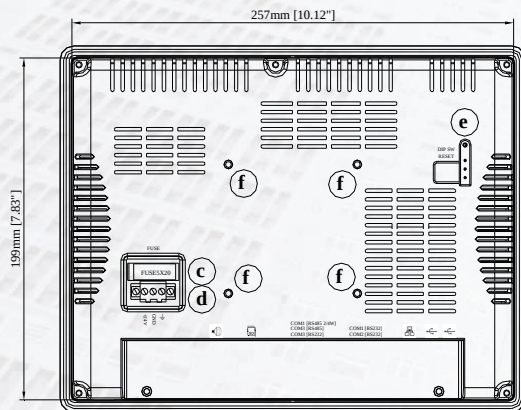

Rear View

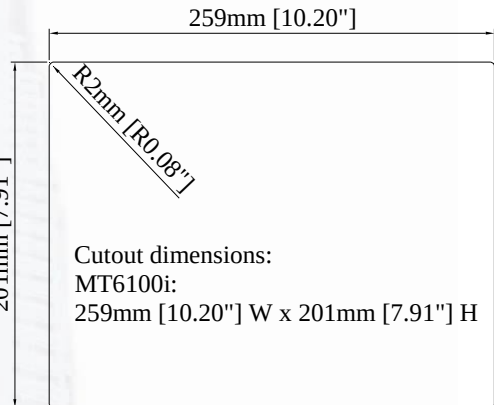

Cutout dimensions:
MT6100i:
259mm [10.20"] W x 201mm [7.91"] H

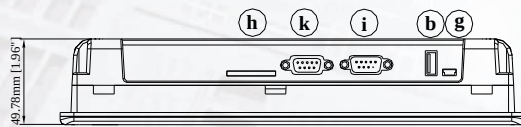

Bottom View

a	N/A	g	USB Client port
b	USB Host port	h	SD card slot
c	Fuse	i	Com1 RS232, Com2 RS232
d	Power connector	j	N/A
e	DIP SW & Reset button	k	Com1 RS485, Com3 RS485, Com3 RS232
f	VESA 75mm screw holes		

Ordering Information

MT6100i:
10" 800x480 TFT LCD HMI, 128MB flash memory/64MB DDR2 RAM on board.

RZCMT6100:
MT6000/8000 i series download cable / Mini USB to USB 2.0 100 cm